

SECTION A-A

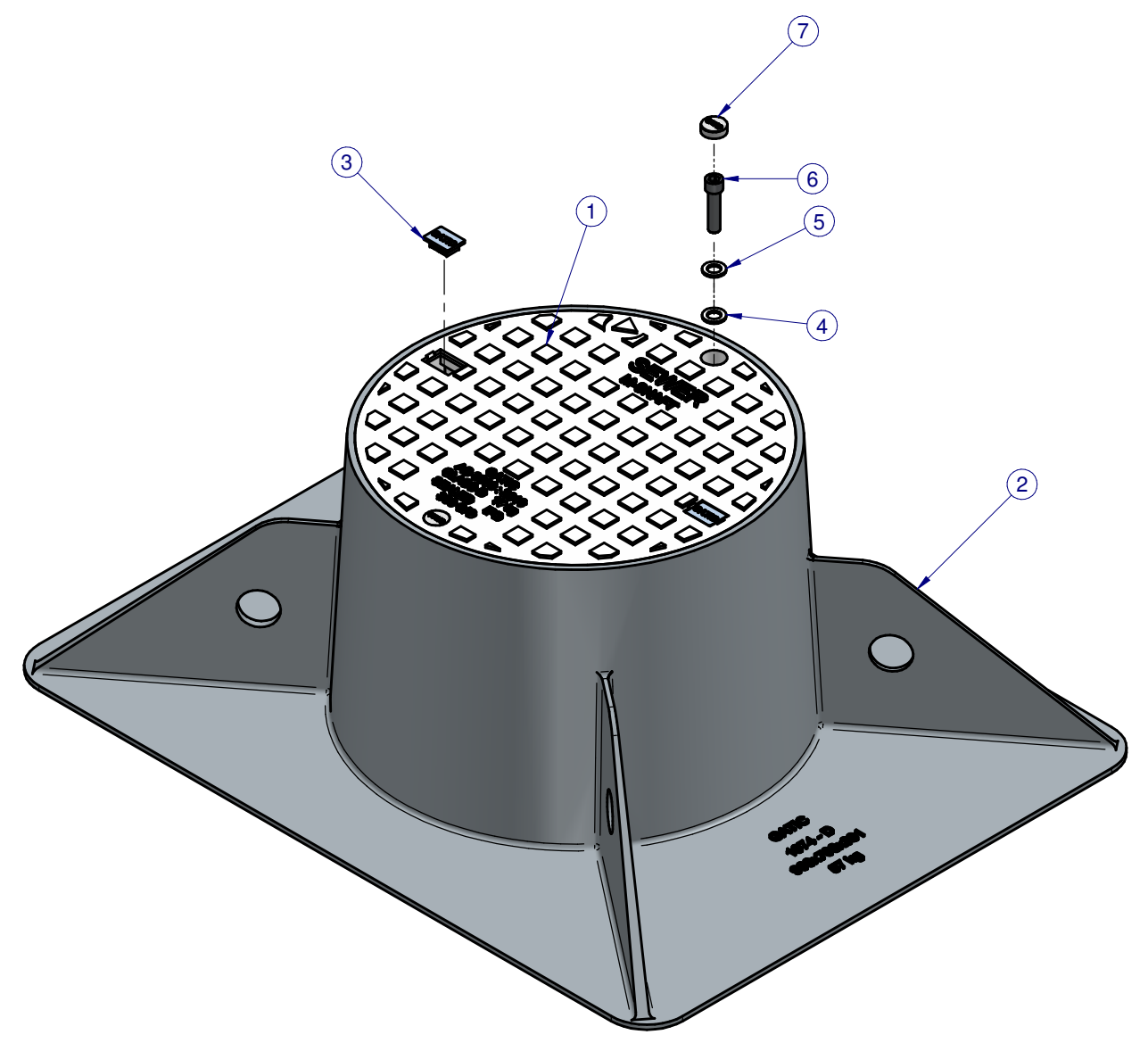
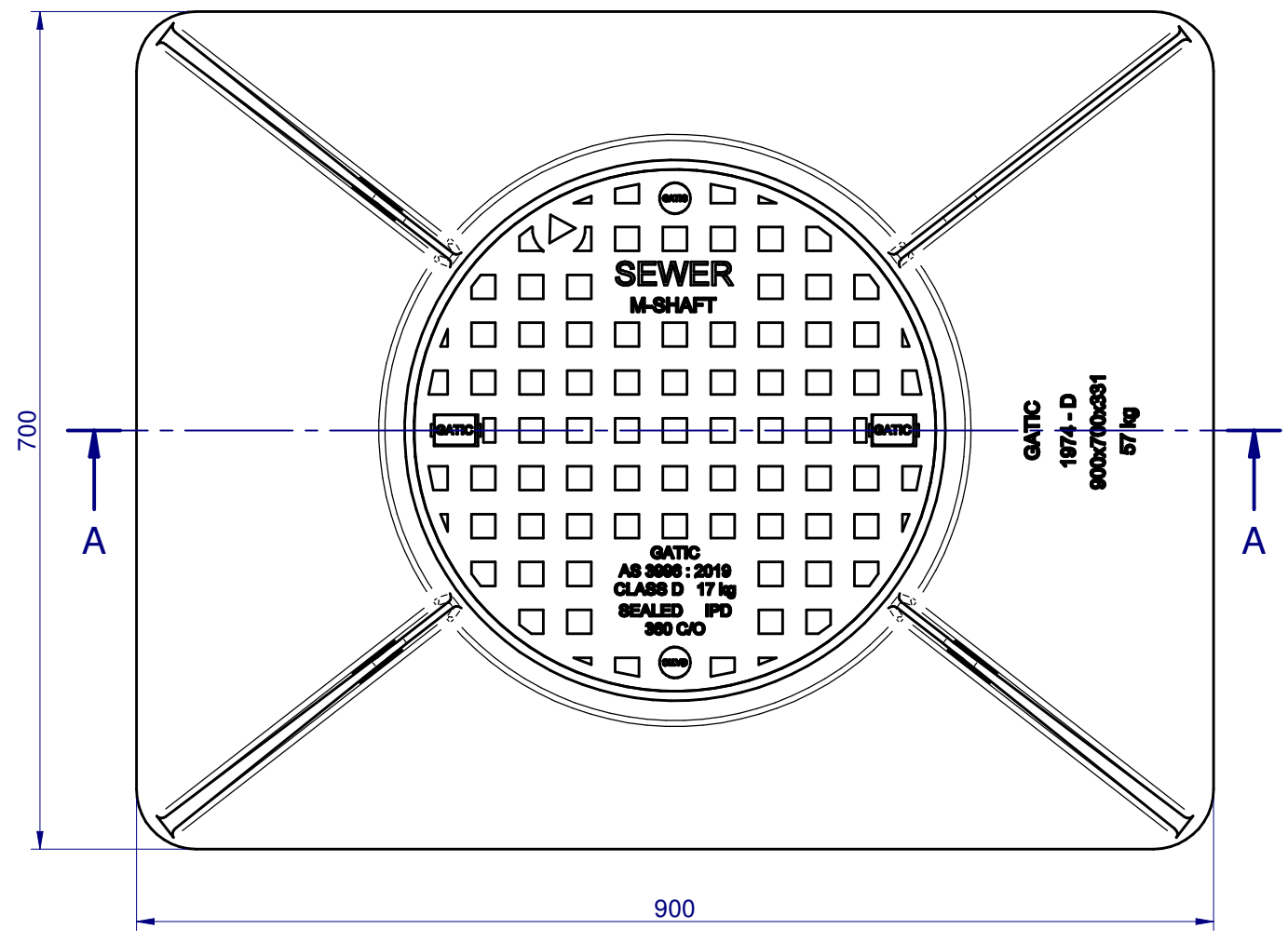

GM300S36D2						
Item #	Drwg #	Rev #	Description	Material	Qty	Mass [kg]
1	1975	E	Ø360 C/O Solid Top Cover Class D	Ductile Iron 500-10	1	17.1 kg
2	1974	D	Ø360 C/O Frame 900x700	Ductile Iron 500-10	1	57.2 kg
3	1681	A	Plastic Keyhole Plug	UV Stabilized Nylon	2	0.0 kg
4	2917	A	M12 Washer	Nylon, general purpose	2	0.0 kg
5	2918	A	M12 Washer	Stainless Steel, A4-70	2	0.0 kg
6	5990	A	M12 x 50 Socket Head Cap Bolt	Stainless Steel, A4-70	2	0.1 kg
7	2854	C	Plastic Plug Ø26 mm	UV Stabilized Nylon	2	0.0 kg

© Copyright : Gatic Pty Ltd - 2020

REVISION	No	DATE	DESCRIPTION	BY	CKD.
E	21-09-20	COVER & FRAME REVISED	F.M.	S.S.	
D	01-05-19	COVER REVISED	F.M.	F.M.	

**UNLESS OTHERWISE STATED**  
 ALL MEASURES IN MILLIMETERS.  
 GENERAL CAST TOLERANCES:  
 CT9 to ISO 8062.  
 CASTING RADII: 3 mm  
 DRAFT TAPERS: 2°

LINEAR MACHINING TOLERANCE:  
 X. ±0.25 mm  
 X.X ±0.10 mm

ANGULAR MACHINING TOLERANCE:  
 X. ±0.5°  
 X.X ±0.1°

NOM = Nominal; O/A = Overall; TYP = Typical; C/O = Clear Opening

**FINISH:** ALL CAST SURFACES TO BE PAINTED AS SPECIFIED. FABRICATED COMPONENTS TO BE HOT DIP GALVANISED TO AS/NZS 4680. LIGHT FILM OF GATIC SEALING GREASE TO BE APPLIED ON ALL MACHINED SURFACES.

**GATIC**  
 GATIC PTY LTD  
 9-15 Radford Road, PO Box 312, Reservoir VIC. 3073  
 Ph- 03 9316 2666 Fax- 03 9315 0099 www.gatic.com.au

THIRD ANGLE PROJECTION

DESIGNED:	BY	DATE
H.C.	H.C.	23-11-04
DRAWN:	BY	DATE
H.C.	H.C.	23-11-04
CHECKED:	BY	DATE
C.A.	C.A.	23-11-04
APPROVED:	BY	DATE
C.A.	C.A.	23-11-04

CODE: GM300S36D2  
 SCALE: N.T.S.  
 FORMAT: A3  
 SHEET: 1 of 1

TITLE: Ø360 C/O MAINTAINENCE SHAFT SOLID TOP COVER & FRAME ASSEMBLY CLASS D  
 MATERIAL: Ductile Iron 500-10  
 MASS: 74.4 kg  
 DRG. No: 1971  
 REV: E